

Temporal Bright and Dark Image Sticking Phenomena of Counter-type Electrodes with Parallel Electric Field in AC-PDP

BO-SUNG KIM,¹ CHOON-SANG PARK,² JAE HYUN KIM,²
YUN-SU LEE,¹ AND HEUNG-SIK TAE^{2,*}

¹Display Nanomaterials Research Center, Kyungpook National University,
Daegu 702-701, Korea

²School of Electronics Engineering, College of IT Engineering, Kyungpook
National University, Daegu 702-701, Korea

The temporal bright and dark image sticking phenomena of the counter structure are compared with those of the coplanar structure. For both the counter and coplanar structures, the temporal bright and dark image sticking phenomena are examined by measuring the IR emission profile, displayed luminance, perceived luminance, and temperature. The bright image sticking and dark image sticking phenomena in the counter structure are lessened, because the influence on the MgO layer is reduced by the small sustain electrode area and the ion sputtering is not given directly damage to phosphor layer by parallel electric field between both sustain electrodes. Accordingly, the temporal bright and dark image sticking phenomena of the counter structure are mitigated.

Keywords AC PDP; counter electrodes; image sticking

Introduction

For a high definition plasma display panel, image sticking remains a critical problem [1,2]. Image sticking is a phenomenon where a previously displayed image appears as a residual image in a consecutively displayed image when the previously displayed image is displayed continuously over a few minutes. Temporal image sticking is normally categorized as temporal bright and dark image sticking. Although a repetitive strong discharge during a sustain period is known to induce image sticking, the image sticking problem is still not clearly understood. The counter sustain electrode structure has a parallel electric field between both sustain electrodes than the coplanar electrode structure [3–5]. Our experimental observation shows that the discharge cell structure, especially electrode structure, is closely related to the temporal bright and dark image sticking phenomenon. For this reason, this paper focuses on the temporal bright and dark background image sticking problem in the counter electrode structure.

*Address correspondence to Prof. Heung-Sik Tae, Kyungpook National University, Sangyuk-dong, Buk-gu, Daegu 702-701, Korea (ROK). Tel.: (+82)53-950-6563; Fax: (+82)53-950-5505. E-mail: hstae@ee.knu.ac.kr

Experimental

Figures 1(a) and (b) show the schematic diagram of a single pixel in the coplanar sustain electrode structure (a) and the proposed counter electrode structure (b) used in this study. For both structures, the vertical and horizontal cell pitches for a single sub-pixel are 693 and

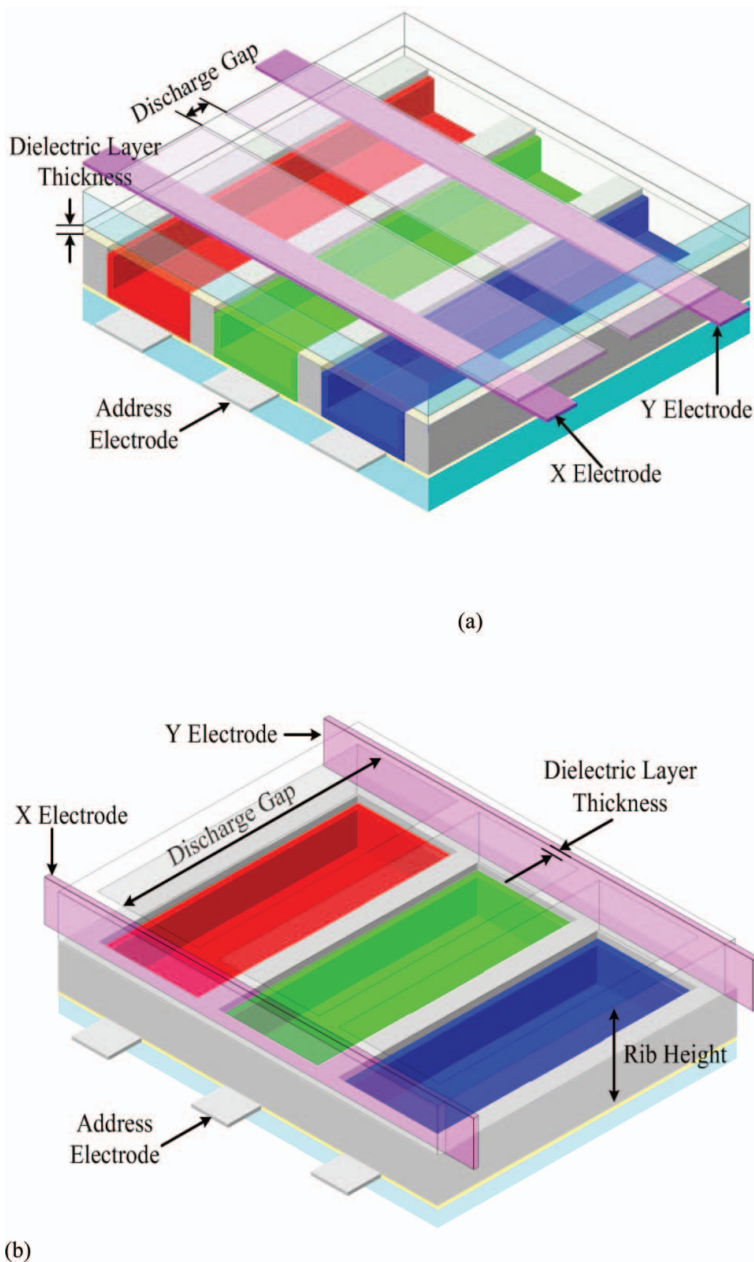

Figure 1. Schematic diagram of 6-in. test panels with: (a) coplanar sustain electrode structure and (b) proposed counter electrode structure.

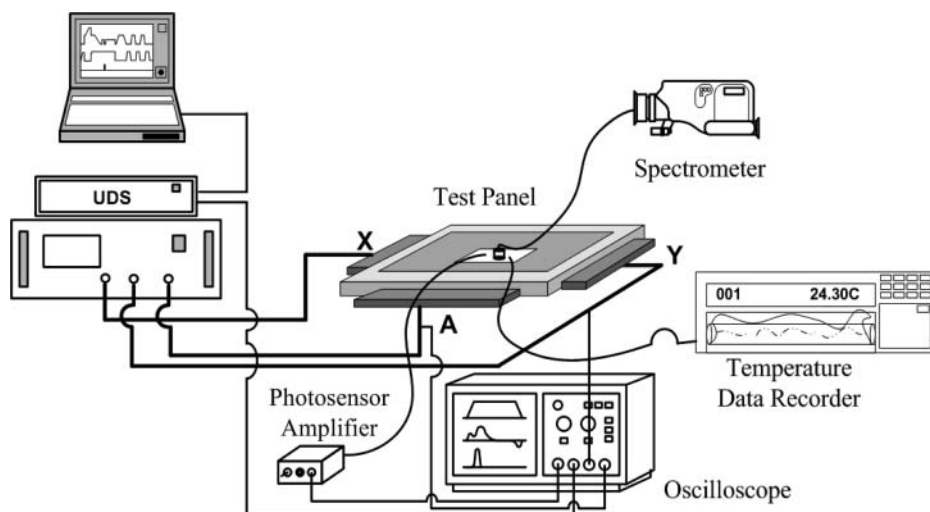

Figure 2. Schematic diagram of experimental setup.

304 μm , respectively. The width of the barrier-rib is 80 μm , the discharge gaps between the two sustain electrodes are 483 μm for counter structure, and 80 μm for coplanar structure, respectively. The barrier-rib height is 120 μm and the thickness of the dielectric layer is 40 μm . An MgO protective layer with a thickness of 0.7 μm is then deposited on the dielectric layer. The gas mixture of Ne-Xe (4%) is filled under the pressure of 450 Torr in the 6-in. test panel. As shown in Fig. 1(a), the coplanar sustain electrodes consist of the bus electrode made from the Ag paste and the transparent ITO (Indium Tin Oxide) sustain electrodes. Whereas, for the face-to-face sustain electrode, only the opaque sustain electrodes made from the Ag paste are immersed within the barrier-ribs with fine grooves fabricated, as shown in Fig. 1(b).

Figure 2 shows the measurement systems employed in this experiment. A spectrometer (PR-715) and a photo sensor amplifier (C6386 ; Hamamatsu 社) are used to measure the changes in the luminance and IR (Infrared) emission during the reset-period, respectively. A signal generator and the driving system (UDS ; FTLAB 社) are used to apply the driving waveform to the test panel. A temperature data recorder (DR230) is used to measure the real-time temperature of each test panel. To produce a residual image caused by image sticking, the measurement point of the test panel is abruptly changed to a dark background image after a 10-minute sustain discharge.

Figures 3(a) and (b) show driving waveforms suitable for the coplanar sustain electrode structure and the counter sustain electrode structure, respectively. The driving waveforms applied to the coplanar sustain electrode structure are the conventional driving waveform, as shown in Fig. 3(a). However, the conventional driving waveforms are not applicable to the counter electrode structure due to the large sustain gap of 300 μm and the short distance between the address and sustain (X or Y) electrodes. Accordingly, modified driving waveforms suitable for the counter electrode structure are applied to the electrodes. Auxiliary address pulses of the counter structure are adopted in the sustain discharge period. The amplitudes of the sustain pulses applied to the counter structure, V_x and V_y , are 230 V. During the reset period, a ramp-bias pulse is applied to the address electrode, whereas positive and negative square pulses are applied to the sustain and address electrodes during

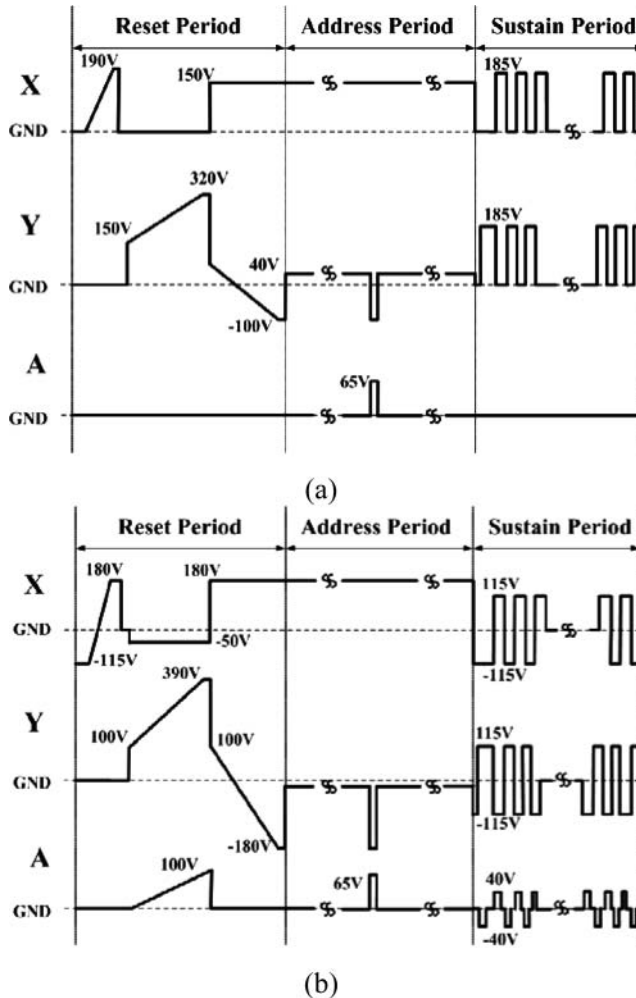

Figure 3. Driving waveforms suitable for (a) the coplanar sustain electrode structure and (b) the counter sustain electrode structure.

the sustain period, as shown in Fig. 3(b). The other driving conditions are as follows: a sustain frequency of 200 kHz, a duty ratio of 50%, and 50 sustain pulses. In addition, in order to facilitate production of the sustain discharge for the counter electrode structure, address bias pulses with an amplitude of 40 and -40 V with a width of $0.5 \mu\text{s}$ are applied.

Results and Discussion

A. Temporal Bright Image Sticking

Figure 4 shows the square-type test image pattern for producing a temporal bright image with three measurement points, A, B, and C. Region B refers to the discharge region whereas regions A and C are non-discharge regions. The differences in the luminance among the three measurement points, A, B, and C, are determined under a bright background image

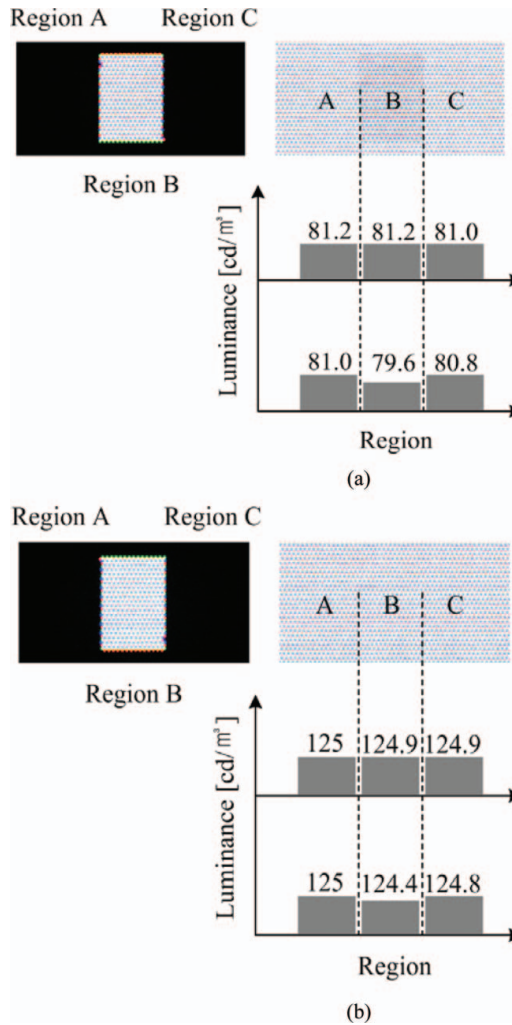

Figure 4. Square-shaped test image pattern and the changes in the luminance measured at point B for both structures; bright image sticking.

after the test image pattern is displayed for 10 minutes. As shown in Fig. 4, in the coplanar electrode structure, the luminance at point B between the cases before and after a 10-minute sustain discharge is decreased by about 1.6 cd/m^2 . On the other hand, in the case of the counter structure, the luminance at point B before and after the 10-minute discharge decreases by about 0.5 cd/m^2 , as shown in Fig. 4. In this case, the decrease in the luminance is attributed to alleviation of the temporal bright image sticking phenomenon. The temporal bright image sticking can be measured in terms of the difference in luminance between cells with and without image sticking. However, when dealing with bright image sticking, the luminance perceived by the human eye should be considered instead of the measured display luminance, because the final estimation for bright image sticking is made by the human viewer. The relation between the perceived luminance, P and the display luminance, L is as follows [6,7].

Table 1. Difference in perceived (ΔP) measured at point B for both cases; bright image sticking

	L1 [cd/m^2]	L2 [cd/m^2]	$\Delta L [= L2 - L1]$	Standard [ΔP_s]	Dark [ΔP_d]
Coplanar	81.2	79.6	1.6	2.74	11.69
Counter	124.9	124.4	0.5	1.75	7.93

Therefore, in the case of the coplanar sustain electrode structure in the image sticking cell (point B), the perceived luminance difference, $\Delta P_s (= P2 - P1)$, for the standard state is 2.74. In contrast, for the bright case, the perceived luminance difference, $\Delta P_d (= P2 - P1)$, is 11.69. In the case of the counter sustain electrode structure in an image sticking cell (point B), the perceived luminance difference $\Delta P_s (= P2 - P1)$ for the standard state is 1.75 and 7.93 for the bright state, as shown in Table 1.

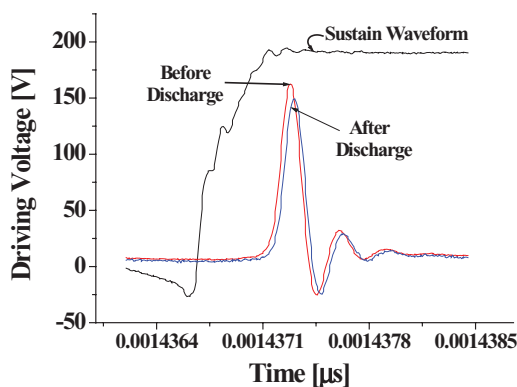

(a)

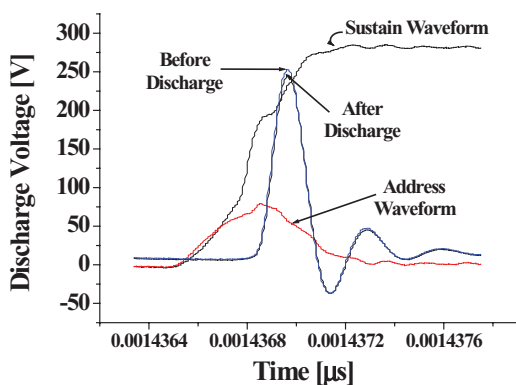

(b)

Figure 5. Changes in the IR (828 nm) emissions measured at point B during sustain-period under background.

Figures 5(a) and (b) shows the changes in the IR emission measured at point B during a sustain period under a bright background condition. In the coplanar structure (a), the IR emission intensity decreased after 10 min, whereas the IR intensity of the counter structure showed little difference with that measured 10 min previously. Consequently, the observation of smaller IR intensity for the counter structure (b) relative to that of the coplanar structure implies that the temporal bright image sticking is mitigated.

B. Temporal Dark Image Sticking

Figures 6(a) and (b) show the difference in luminance among the three measurement points under a dark background image after a test image pattern is displayed for 10 minutes. In

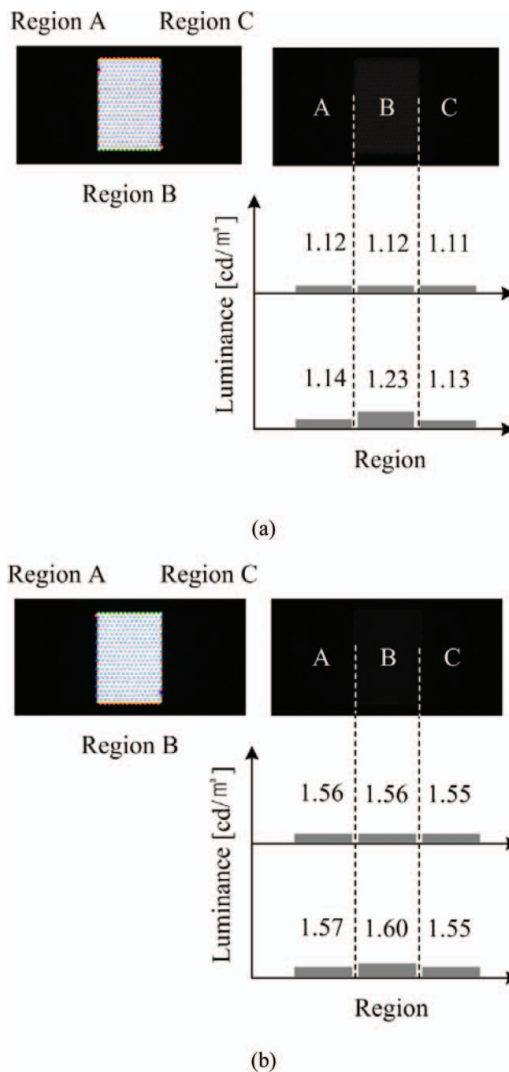

Figure 6. Square-shaped test image pattern and the changes in the luminance measured at point B for both structures; dark image sticking.

Table 2. Difference in perceived (ΔP) measured at point B for both cases; dark image sticking

	L1 [cd/m^2]	L2 [cd/m^2]	$\Delta L [= L2 - L1]$	Standard [ΔP_s]	Dark [ΔP_d]
Coplanar	1.12	1.23	0.11	0.0871	0.3291
Counter	1.56	1.60	0.04	0.0264	0.0918

the coplanar electrode structure, the luminance at point B between the cases before and after a 10-minute sustain discharge is increased by about $0.11 \text{ cd}/\text{m}^2$ (9.80% up), whereas the luminance of the counter structure at point B before and after the 10-minute discharge increases by about $0.04 \text{ cd}/\text{m}^2$ (2.6% up). In the case of the coplanar sustain electrode structure in the image sticking cell (point B), the perceived luminance difference, ΔP_s ($= P2 - P1$), for the standard state is 0.0871. On the other hand, for the dark case, the perceived luminance difference, ΔP_d ($= P2 - P1$), is 0.3291. In the case of the counter sustain electrode structure in the image sticking cell (point B), the perceived luminance difference ΔP_s ($= P2 - P1$) for the standard state is 0.0264 and 0.0918 for the dark state, as shown in Table 2. Therefore, the variation of the perceived luminance of the counter structure is also lower than that of the coplanar structure.

Figure 7 shows the changes in the IR (828 nm) emission measured at point B during a reset period under a dark background condition. In both cases, the IR emission intensity

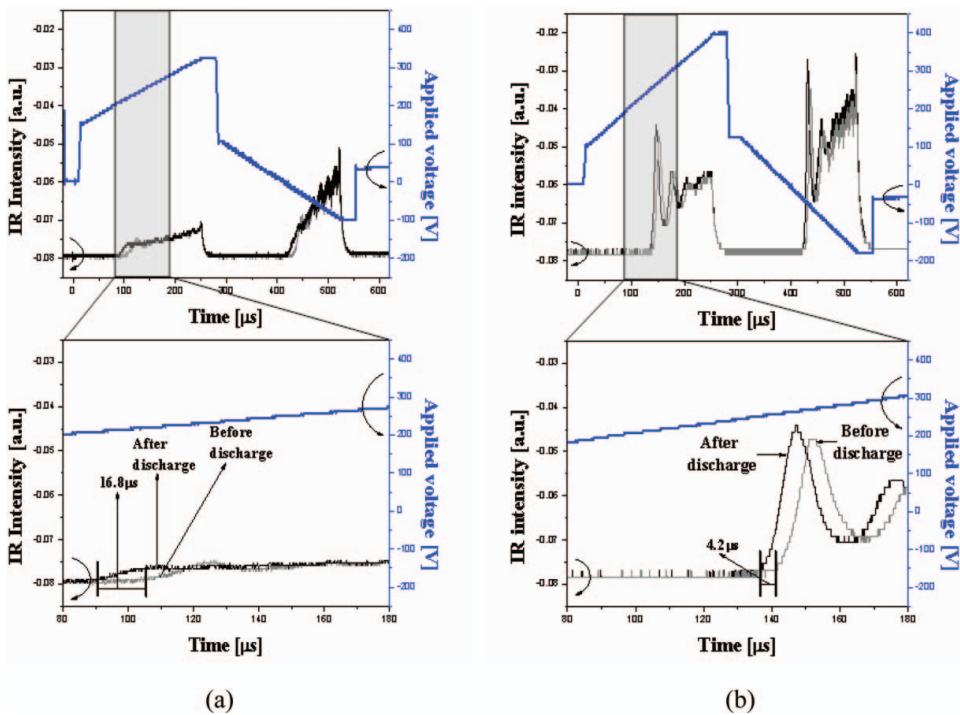
**Figure 7.** Changes in the IR (828 nm) emissions measured at point B during reset-period under dark background.

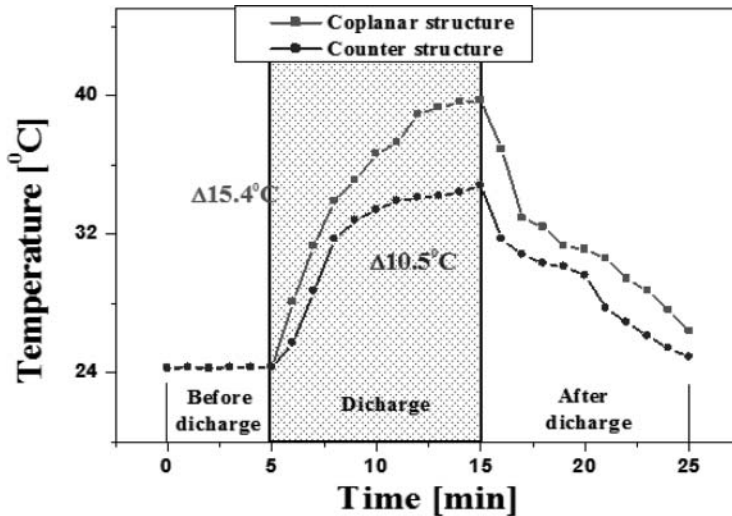

Figure 8. Changes in the panel temperature measured during 10-min sustain discharge for both structure.

increased slightly and the IR emission waveform is shifted to the left direction after a 10 min. sustain discharge. The IR waveform is shifted to the left by $16.8 \mu\text{s}$ for the coplanar structure and by $4.2 \mu\text{s}$ for counter structure. This can be explained as follows: The IR emission from the image sticking cells is shifted to the left, meaning that the firing voltage is reduced in the image sticking cells due to the strong sustain discharge lasting for a period of 10 min. Consequently, the smaller shift of IR ignition for the counter structure relative to that of the coplanar case implies the temporal dark image sticking is mitigated in the case of the former. To investigate the relation between the mitigation of temporal dark image sticking and the temperature rise induced by the 10 min. sustain discharge, a temperature data recorder is used to measure the panel temperature difference.

Figure 8 shows the changes in the panel temperature measured at point B for both structures before and after the 10-minute sustain discharge. In both cases, the panel temperature increase on the front glass is caused by the iterant strong sustain discharge within the cell. In the coplanar structure case, the temperature increased by 15.4°C , whereas in the counter structure it increased by 10.5°C . The smaller rise in temperature in the counter case than that in the coplanar case can be attributed to the existence of ITO layer in the cell of the latter. The counter structure is an ITO-less structure, and therefore the temperature increase by the high resistivity of the ITO layer can be eliminated. Therefore, the temporal dark image sticking phenomenon is alleviated by the counter electrode structure.

Conclusions

The temporal bright and dark image sticking phenomena for both structures are examined by measuring the IR emission profile, the displayed luminance, the perceived luminance, and the panel temperature. The temporal bright image sticking can be measured in terms of the difference in luminance between cells with and without image sticking. After 10 minute discharge, the changes in IR intensity and luminance of the counter structure are smaller than those of the coplanar structure. In the case of dark image sticking, after a 10 minute

discharge, the changes in IR intensity and luminance of the counter structure are smaller than those of the coplanar structure. The IR waveform is shifted to the left by 16.8 μ s for the coplanar structure and by 4.2 μ s for counter structure. In the coplanar structure case, the temperature increased by 15.4°C, whereas in the counter structure it increased by 10.5°C. The smaller rise in temperature in the counter case than that in the coplanar case can be attributed to the existence of ITO layer in the cell of the latter. The counter structure is an ITO-less structure, and therefore the temperature increase by the high resistivity of the ITO layer can be eliminated. As a result, the temporal bright and dark image sticking phenomena are alleviated by the counter electrode structure.

Acknowledgment

This work was supported in part by the Basic Science Research Program through the National Research Foundation of Korea (NRF) funded by the Korean Ministry of Education, Science and Technology (2012-0004506) and in part by Brain Korea 21 (BK21).

References

- [1] Tae, H.-S., Park, C.-S., Cho, B.-G., Han, J.-W., Shin, B. J., Chien, S.-I., & Lee, D. H. (2006). *IEEE Trans. Plasma Science*, 34, 996.
- [2] Park, C.-S., Tae, H.-S., Kwon, Y.-K., & Heo, E. G. (2007). *IEEE Trans. Electron Devices*, 54, 1315.
- [3] Kim, B.-S., & Tae, H.-S. (2009). *Mol. Cryst. Liq. Cryst.*, 499, 213–223.
- [4] Kim, B.-S., Tae, H.-S., Cho, T. S., Choi, Y. D., Kim, J. N., Lee, K. S., Terao, Y., Miyama, T., & Yamada, Y. (2007). *In Proc. SID' 07 Dig.* p. 542.
- [5] Kim, J.-H., Park, C.-S., Kim, B.-S., Park, K.-H., & Tae, H.-S. (2007). *Journal of Information Display*, 8, 3.
- [6] Stevens, J. C., & Stevens, S. S. (1963). *Journal of the Optical Society of America*, 53, 375.
- [7] Yamada, M., Ishii, M., Shiga, T., & Mikoshiba, S. (2002). *In Proc. SID' 02 Dig.* p. 940.